

surgeassure™

CABLE/PHONE SURGE PROTECTOR

SATHW2 & SATH2

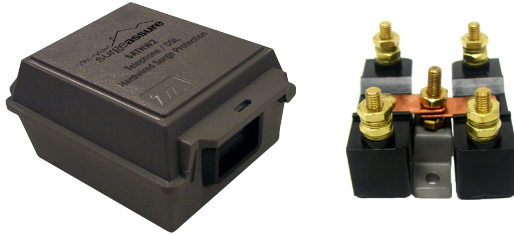

FEATURES & BENEFITS

- UL listed surge protection
- Hardwired Modem/Fax/DSL protection
- Easy to install
- Exceptionally fast response time
- Available with or without enclosure
- 5 Year Product Warranty

The surgeassure™ SATHW2 is a 2 pair, hardwired surge protector for telephone, DSL or modem connected electronics in residential and light commercial applications. The SATHW2 protects against electrical power surges that can enter through the main telephone connection and is equipped with a failshort device to permanently ground the telephone line in the event of a power cross. The SATHW2 is housed in a weatherproof enclosure to facilitate indoor or outdoor applications. The enclosure is molded of temperature and humidity resistant thermoplastic to resist cracking and discoloration. The cover can be secured with a tie wrap or similar locking device.

The surgeassure™ SATH2 is the same 2 pair, hardwired surge protector for telephone, DSL or modem used in the SATHW2 but without the weatherproof enclosure. The SATH2 is designed for indoor applications or can be mounted inside another weatherproof enclosure for outdoor mounting applications.

The surgeassure™ warranty covers product defects for 5 years.

To have complete protection for your equipment, home, or business, it is important to protect AC power lines and all data lines the equipment is connected through.

REPLACEMENT PARTS

CATALOG #	DESCRIPTION
SATHW2	TM1P - 1 Pair Protection Module (2 required) THWE2 - Weatherproof Enclosure, 2 Pair Capacity
SATH2	TM1P - 1 Pair Protection Module (2 required) TB1 - Ground Stud Mounting Adaptor



TECHNICAL SPECIFICATIONS

HARDWIRED TELEPHONE SURGE PROTECTION

Catastrophic Surge Circuit	Yes
Spike Capacity	250A
Let Through Voltage	300V
Over Current Protection	Yes
Response Time	<1 nanosecond
Environmentally Sealed	Yes

AGENCY APPROVALS & WARRANTY

UL Listings	497
Product Warranty	5 Years

DIMENSIONS

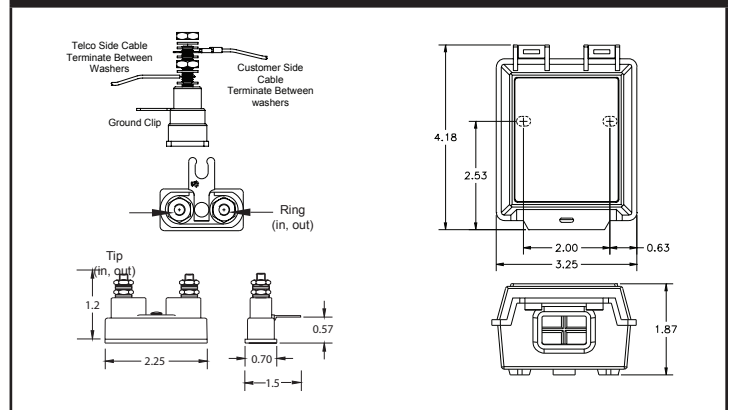

INSTALLATION INSTRUCTIONS

DO NOT INSTALL DURING ACTIVE STORM CONDITIONS.

This device can be used indoors (SATH2), or outdoors when installed in weatherproof housing (SATHW2). Failure to follow installation instructions can result in personal injury and/or equipment damage not covered by warranty.

SATH2 – For indoor use:

- 1) SATH2 protects 2 pair (1 pair per protector module) and is intended for indoor use only, with out additional housings.
- 2) Attach securely to mounting surface.
- 3) Install ground wire, and if applicable, service shield, under top center nut of mounting bracket and tighten nut securely.
- 4) TIP IN and TIP OUT are connected to one post. RING IN and RING OUT are connected to the second post on the protection module.
- 5) Connect one pair (tip and ring) under the bottom nut on each protector module, tip on one post, ring on the other.
- 6) Connect the customer wiring, tip and ring, under the top nut on the same protector module (protector is wired in parallel).
- 7) Repeat Tip and Ring Connections on second protection module
- 8) Check all wiring for loose connections and shorting or broken wires.

SATHW2 – For outdoor use:

- 1) Mount weatherproof housing securely to flat surface.
- 2) Conductors will enter and exit from the flexible grommet located at bottom of enclosure.
- 3) Follow instruction above for SATH2 connections.
- 4) Secure enclosure with tie wrap or similar locking device.

The SATH2 is a Parallel Device.